

MANUAL  
**MOVEX**®

---

**PREXC  
PREXD**

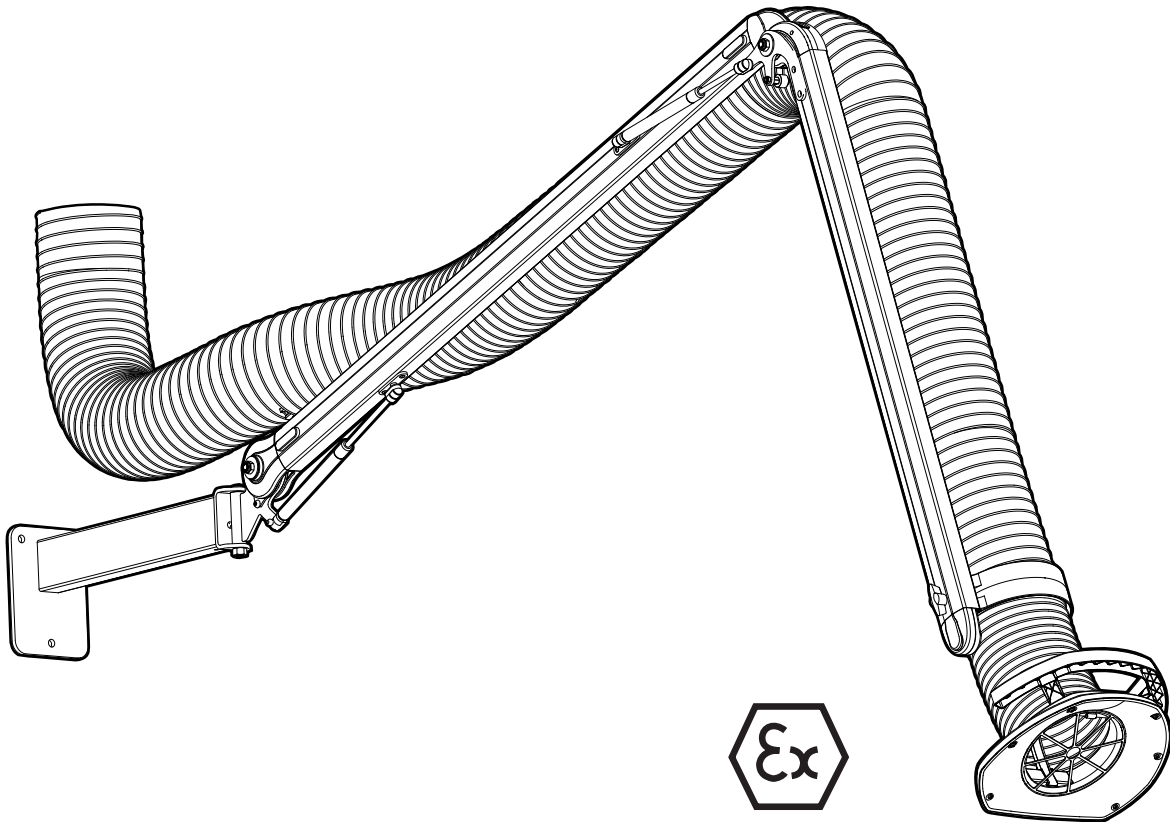

Movex Inc,  
Phone: 610 440-0478 Fax: 610 440-0480  
[www.movexinc.com](http://www.movexinc.com)

## Contents

Important information	3
Applications	3
Technical data	4
Installation and use	5-8
Cleaning	9
Service and repairs	9
Spare parts and accessories	10-11
Testing and troubleshooting	12
Log book for measuring resistance	12

## Important information

NOTE: Read the instructions carefully before installing and using this equipment.

The local extractor in the PR EXC/EXD series is designed to meet the requirements in the ATEX directive 94/9/EC, applicable to equipment intended for use in potentially explosive atmospheres. In order to maintain explosion proof integrity, you must observe the instructions in this manual. Only personnel with the right qualifications may handle this equipment when installing or for service and repairs. Only use original spare parts when repairing the equipment in order to maintain explosion proof integrity. Contact your nearest dealer or head office when purchasing spare parts or if you have technical queries.

Note that all other equipment in the explosively hazardous environment must also be intended for use in this environment to avoid any risk of explosion.

## Applications

The local extraction in the PR EXC/EXD series is intended for use in environments where the atmosphere may be explosive as a result of air and gas mixtures, mist, steam or dust, in otherwise normal circumstances as regards temperature and air pressure. The equipment thereby meets the requirements for equipment category 2 for gas and dust, which means that it is suitable for use in zones 1 or 21, where gas or dust can sometimes be expected to occur. This means that the equipment is also suitable for use in zones 2 or 22, where gas or dust occurs only occasionally.

Do not use the equipment in environments where there are substances that attack or react with the material it consists of, see material specification in "Technical data", as such substances may degrade the explosion proof integrity of the equipment or cause a risk of explosion when reacting. If in doubt, contact your nearest dealer or head office.

The equipment should not be used for non-conductive dust with MIE < 4 mJ if there is a risk that the dust is, or could become, highly charged (MIE = Minimum Ignition Energy).

Do not hang objects or suchlike on the arm as it is not designed for such purposes. Note that the proprietor is responsible for the classification and zone division of the workplace.

## Technical data

Suitable for use in zones	1, 2 (gas) och 21, 22 (dust)
Rec. ambient temperature	+50°F to +125°F
Rec. air velocity to avoid dust accumulation	34-42 cfm
Dimensions of hose/ suction head	Ø4, 5, 6 and 7 <sup>7/8</sup> inch.

### Material PR EXC/EXD:

Wall bracket	Steel with conductive epoxy/PES- powder coating, R< 50kΩ
Horizontal arms	Steel with conductive epoxy/PES- powder coating, R< 50kΩ
Arm system	Aluminium with conductive epoxy/PES- powder c., R< 50kΩ
Plastic details	Conductive PP, R< 200kΩ
Attachment	Stainless steel
Hood plate	Stainless steel
Gas springs	Stainless steel
Friction discs	Stainless steel
Damper blade	Conductive PP, and TPE
Hose strap	PA

### Hose PR EXC/EXD:

EXC	Conductive PE-hose with steel spiral, R<10 <sup>4</sup>
EXD	Antistatic PU-hose with SS-spiral, R< 1TΩ

# Installation and use

The equipment can be delivered partially assembled and installed as per the following description. The equipment can be mounted on a wall or to the ceiling using special brackets, see "Spare parts and accessories". Measure a suitable height for the bracket before mounting the arm to the wall, and check that the existing air duct reaches the hose when fitting to the ceiling, see figures.

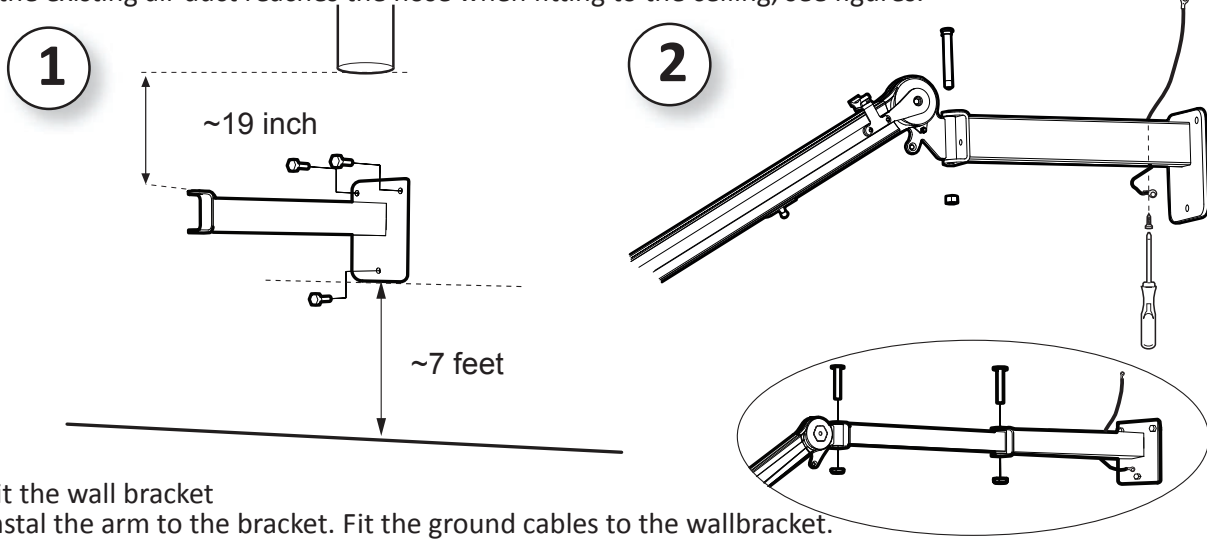

- 1) Fit the wall bracket
- 2) Instal the arm to the bracket. Fit the ground cables to the wallbracket.

Use attachment that is dimensioned for the weight of the arm. Also check that the bearing capacity of the wall or ceiling is adequate.

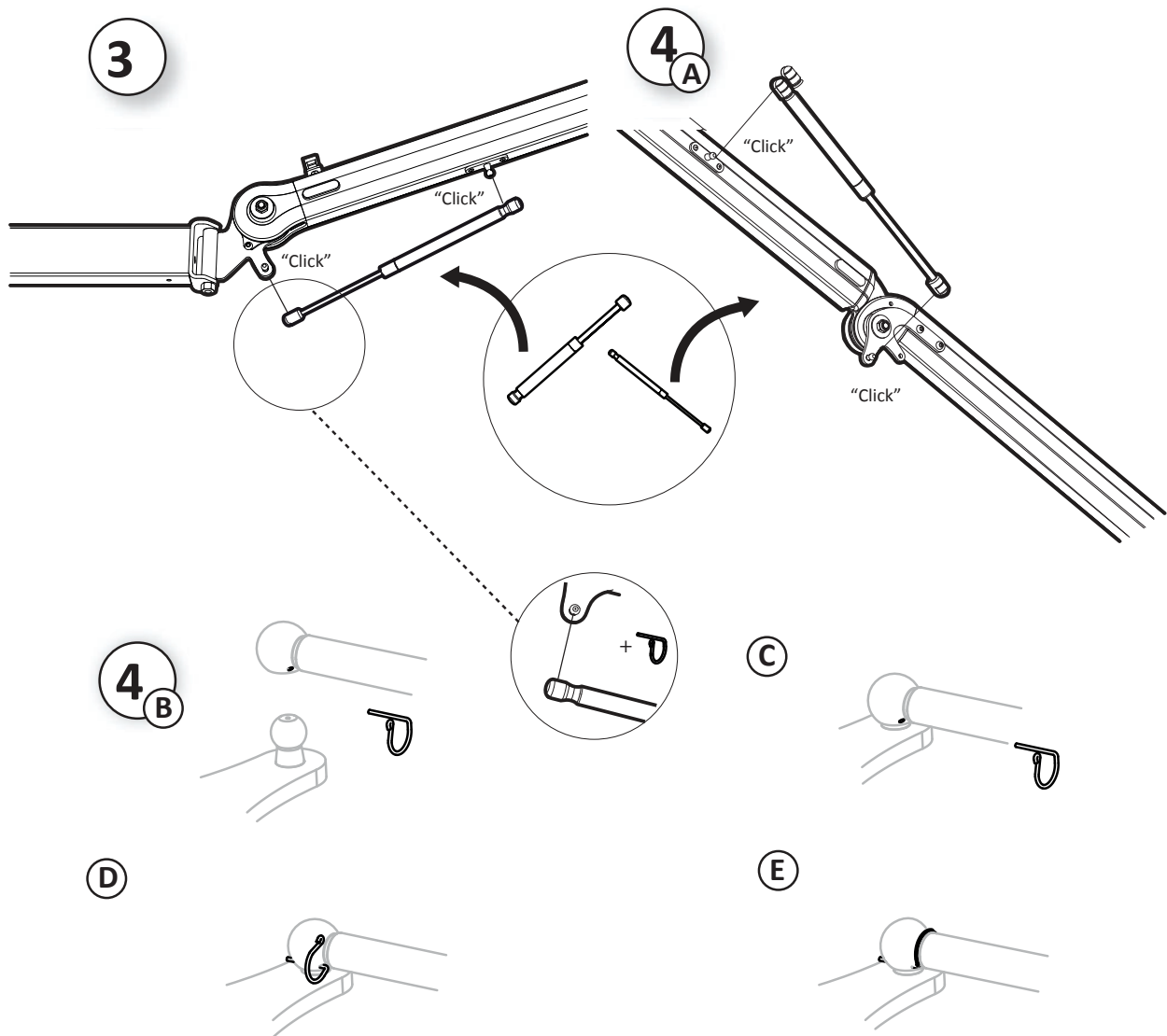

5

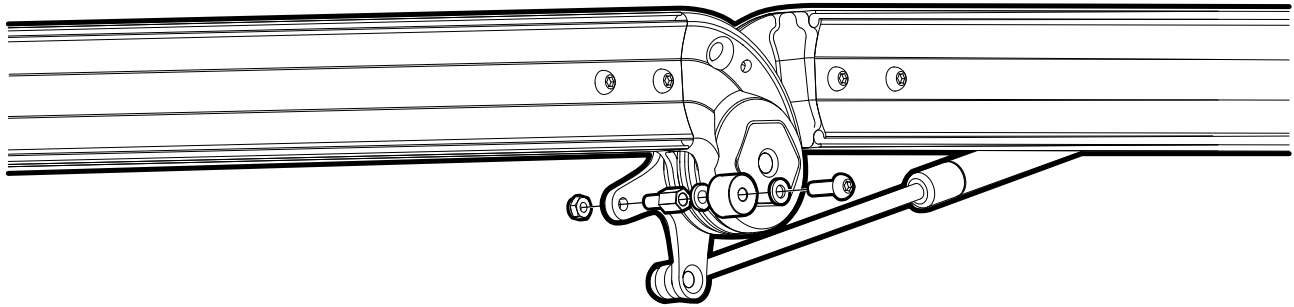

6

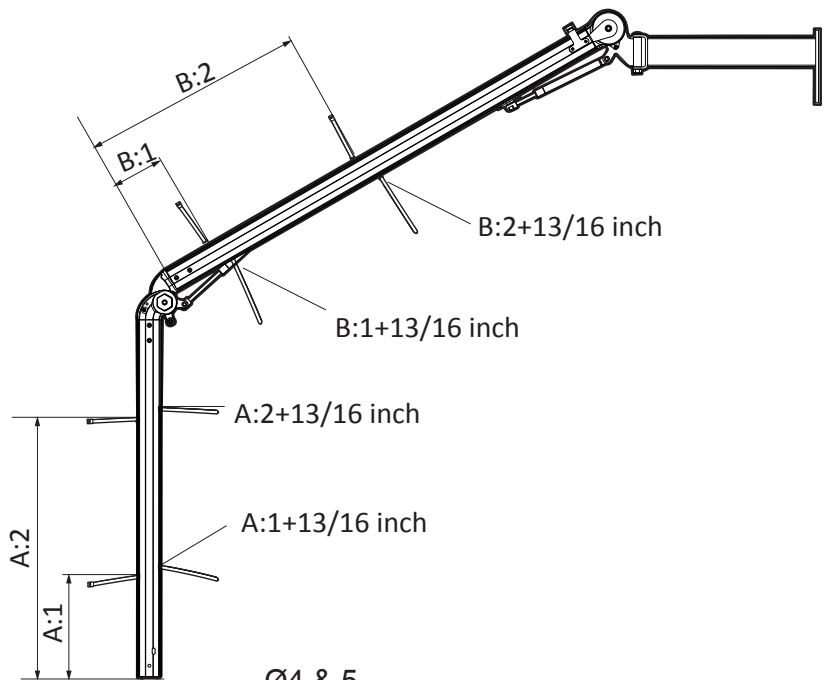
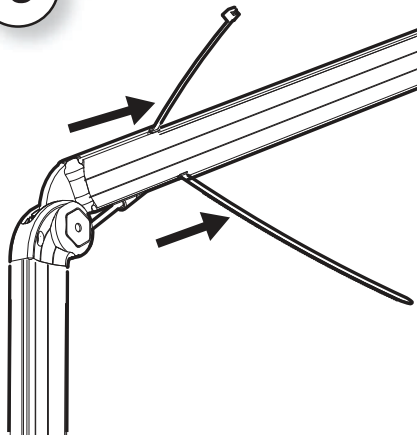

Ø4 & 5

(inches)	A:1	A:2	B:1	B:2
<b>PR 1500</b>	13	-	6	-
<b>PR 2000</b>	13	-	6	20
<b>PR 3000</b>	17	33	6	32
<b>PR 4000</b>	17	33	6	32

Ø6 & 8

(inches)	A:1	A:2	B:1	B:2
<b>PR 1500</b>	11	-	8	-
<b>PR 2000</b>	11	-	8	20
<b>PR 3000</b>	17	31	8	32
<b>PR 4000</b>	17	31	8	32

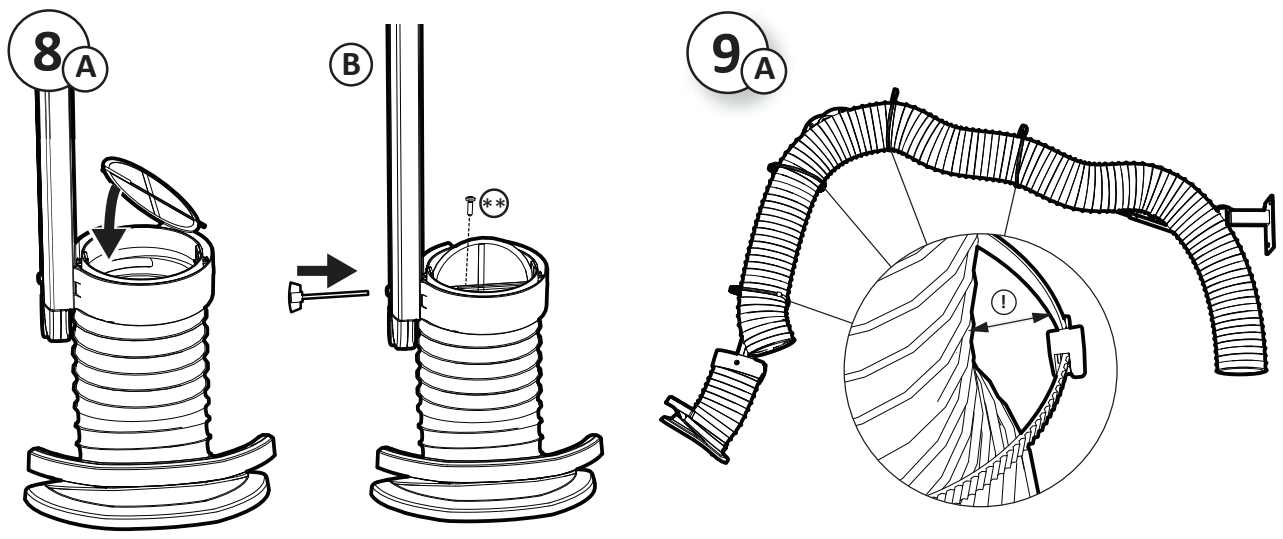
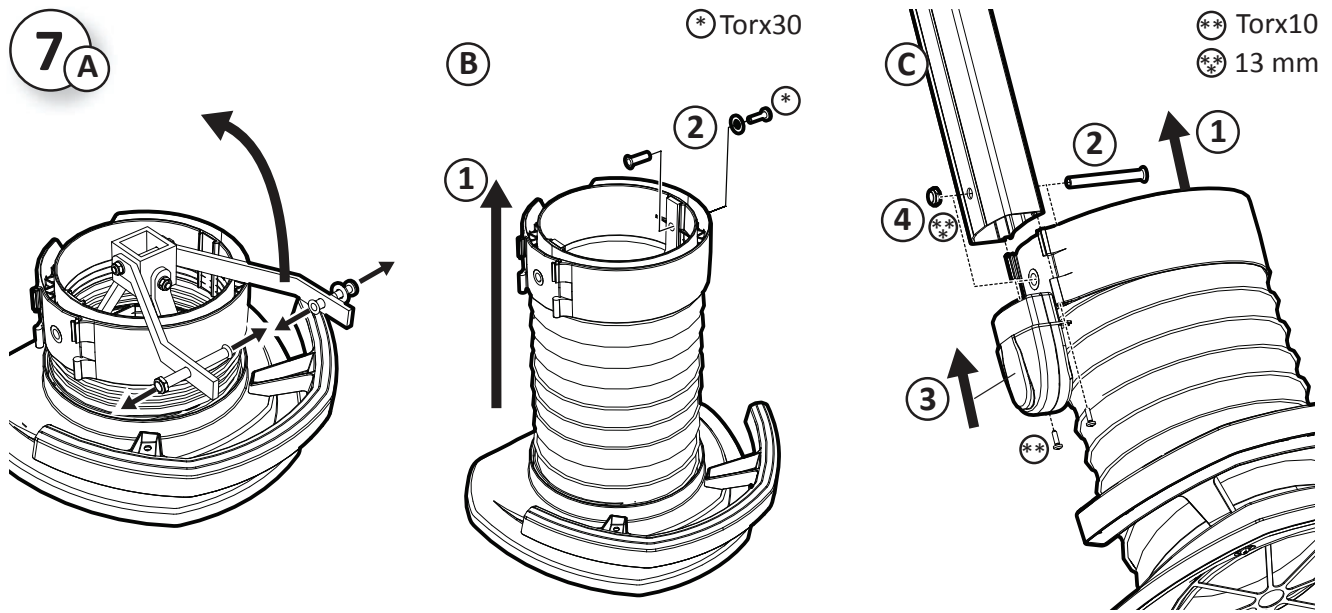

7) Fit the suction nozzle.  
 8) Fit the damper.  
 9) Ensure that the hose is long enough to enable full mobility over the joints, and stretch the hose over the long sections before tightening the mounting strap in the correct order starting with the suction head.

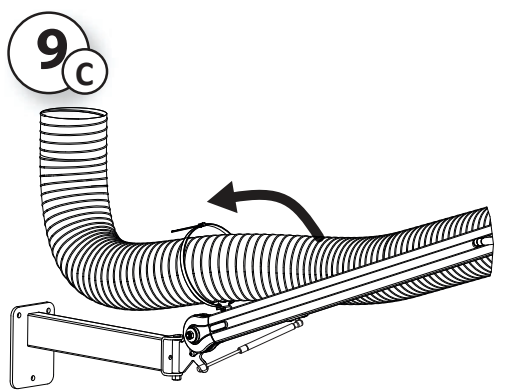
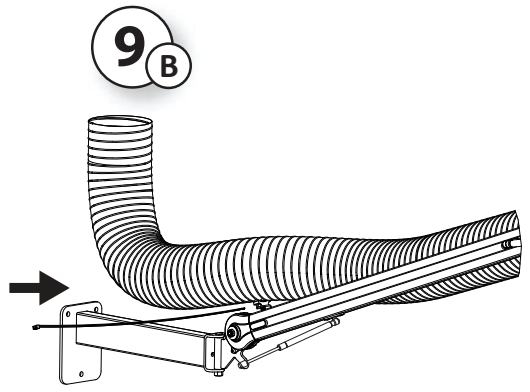

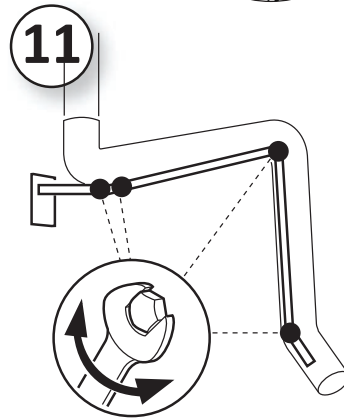
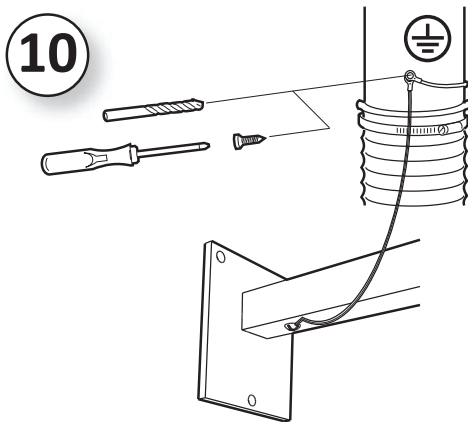
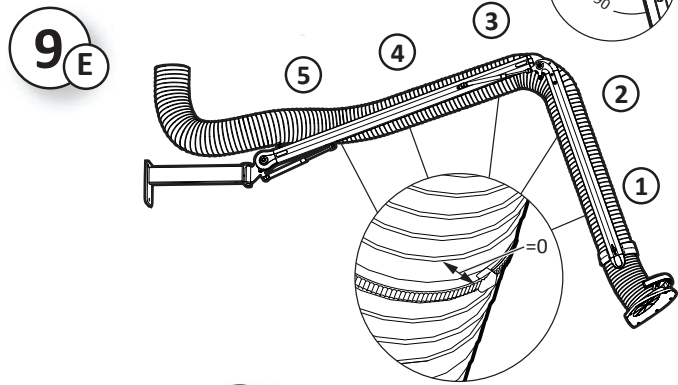
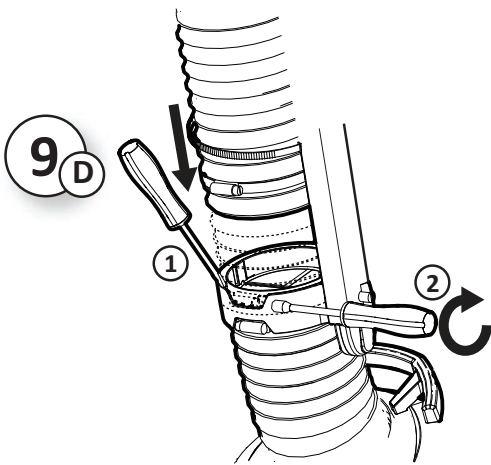

10) Secure the hose to the existing air duct with the accompanying clamp and screw the hose's ground connection to the air duct. Ensure that proper electrical contact is made.  
Connect the ground cable on the bracket to a suitable connection point with the grounding system of the installation.

**Important:** Take the appropriate action if a risk of corrosion has been assessed at the connection point.

11) Tighten the friction joints to an appropriate torque allowing the extraction arm to be easily set and retain its set position without dropping. Where applicable, check that the ground cables across the joints move freely in all directions and that there is no risk of them getting caught in the arm or other objects.

**Important:** Prior to initial operation, the resistance of the arm must have been measured at a satisfactory value as per "Testing and troubleshooting" and the connection to the earth system must have been checked.

Dismantle in the reverse order. Open the mounting straps by releasing the catches in the bushing while tightening the strap. If the equipment is dismantled and the mounting straps cannot be reused for assembly, fit new, original mounting straps. Ensure that the ground connections to the hose are not damaged when dismantling.

## NOTE:

Personnel working in environments where an explosive atmosphere may arise, as well as all other people that enter the area, must be aware of the risks involved.

- Ensure that sparks or objects that may give rise to sparks are not sucked in.
- Guard the suction head and supporting arm against impacts from hard objects.
- When extracting different kinds of dust in combination, start by ensuring that the mix is not ignitable, such as grinding dust from iron in combination with aluminium dust.
- Ensure that objects or people that may be electrostatically charged cannot come into contact with the equipment.
- Avoid charging of non-conductive dust.
- Avoid hygroscopic dust or dust that may stick
- Exercise caution where hybrid mixtures of gas and dust are involved, as they are more easily ignited than the safety data shows individually for the solvent and powder used.

## Cleaning

Clean the extraction arm in the same way as the other equipment at the worksite, however, at least once a year.

Clean when there is no risk of explosion in the environment. Observe the risk of electrostatic discharge from people or cleaning tools where there are dust deposits. People are recommended to wear semi conductive shoes and suitable clothing when cleaning where there is dust with MIE < 30 mJ.

Wear respiratory protective equipment and other appropriate personal safety equipment when cleaning.

For dry cleaning: Vacuum and dry externally and internally where necessary.

For wet cleaning: Check that the solvent does not attack any of the material used in the equipment, see "Technical data". Observe manufacturer dosing instructions. Allow the equipment to dry before using again.

Hoses that need to be cleaned internally may have to be removed (see "Assembly, initial operation and use"). Clean dry or wet, let the components dry and fit them together again.

Remeasure the resistance to ground as per "Testing and troubleshooting" before using the extraction arm again.

## Service and repairs

In addition to the routine cleaning, the equipment must be remeasured with respect to the resistance where necessary, or at least twice per year as per "Testing and troubleshooting". Remeasure each time the equipment is worked on.

You should check the connections at the earth lines, spiral hose and earth point at the same time as the resistance measurement in order to identify any corrosion or loose connections. This is particularly important if the equipment is used in damp or corrosive environments.

Carry out service and repairs when there is no risk of explosion in the environment. People are recommended to wear semi conductive shoes and suitable clothing when servicing where there is dust with MIE < 30 mJ.

Adjust the friction joints in the supporting arm where necessary or at least once a year.

Only use original spare parts when needed; see "Spare parts and accessories".

## Spare parts and accessories

Always state the type designation and serial number of the arm (see rating plate on arm), the number of required spares and the spare part name and number as per the list below, when ordering spare parts or accessories.

Ceiling brackets in EX design are available as accessories for PR EXC/EXD arms. Fit these according to the instructions in this manual; see "Installation and use". Never use any other accessories for PR EXC/EXD arms as this may jeopardize the explosion protection.

- |                        |                                   |                                |
|------------------------|-----------------------------------|--------------------------------|
| 1. Screw (Torx10)      | 18. Damper                        | 34. Upper gas damper           |
| 2. Hood plate          | 19. Clip                          | 35. Upper support arm          |
| 3. Hood with handle    | 20. Hose clamp                    | 36. Gas damper strut           |
| 4. Screw (Torx15)      | 21. Suction nozzle hose           | 37. Pop nut                    |
| 5. Lower joint brace   | 22. End cap                       | 38. Hose                       |
| 6. Screw (Torx30)      | 23. Strap female                  | 39. Upper joint                |
| 7. Friction washer     | 24. Strap male                    | 40. Stud                       |
| 8. Spring washer       | 25. Lower support arm             | 41. Friction washer            |
| 9. Nut                 | 26. Lower joint lower support arm | 42. Washer                     |
| 10. Joint node         | 27. Lower joint upper support arm | 43. Nut                        |
| 11. Upper joint brace  | 28. Friction washer               | 44. Friction plate upper joint |
| 12. Attachment collar  | 29. Gas damper strut              | 45. Screw                      |
| 13. Screw (Torx30)     | 30. Anchoring nut                 | 46. Nut                        |
| 14. Short center shaft | 31. Screw (Torx30)                | 47. Wall bracket               |
| 15. Long center shaft  | 32. Cover cap                     | 48. Horizontal support arm     |
| 16. Nut                | 33. Lower gas damper              | 62. Ground cable 0,60m         |

Always state the type designation and serial number when ordering spare parts or accessories.

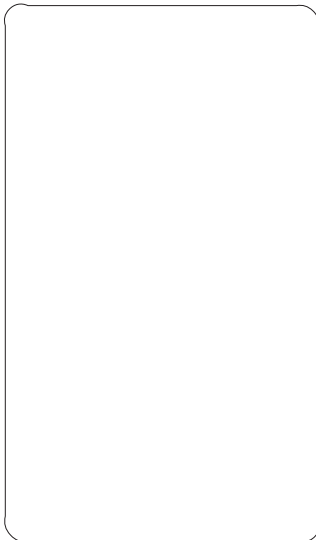

# PR EXC/EXD

