



MF 2000

Mobile weld-fume filter for temporary worksites

The MOVEX weld-fume filter MF is a handy tool for temporary worksites.

The mobile filter MF offers a high level of filtration and high extraction capacity. It is equipped with a gas spring balanced extraction arm (PR), 6 alt. 9 feet long.

The smooth inside of the extraction arm helps reduce the risk of ducts being blocked.

All necessary adjustments can easily be taken care of from the outside

Carbon filter cartridges for gas-mixed air are available on request.

The filter is easily maneuverable due to four pivot wheels.

N.B! The portable filter is not intended for extraction of liquids!

Extraction capacity: about 705 cfm with PR-arm Ø 6 inches.

The MOVEX MF filter is delivered with cable and plug for 1-phase 115 V ~ connection.

*2 different options available,
MF 2000 With a PR 2000-160
or
MF 3000 with a PR 3000-160*

The Movex range also includes fans, accessories, automatic control gear and filters for extraction

**LOCAL EXTRACTOR
Pure advantage**

MOVEX MF

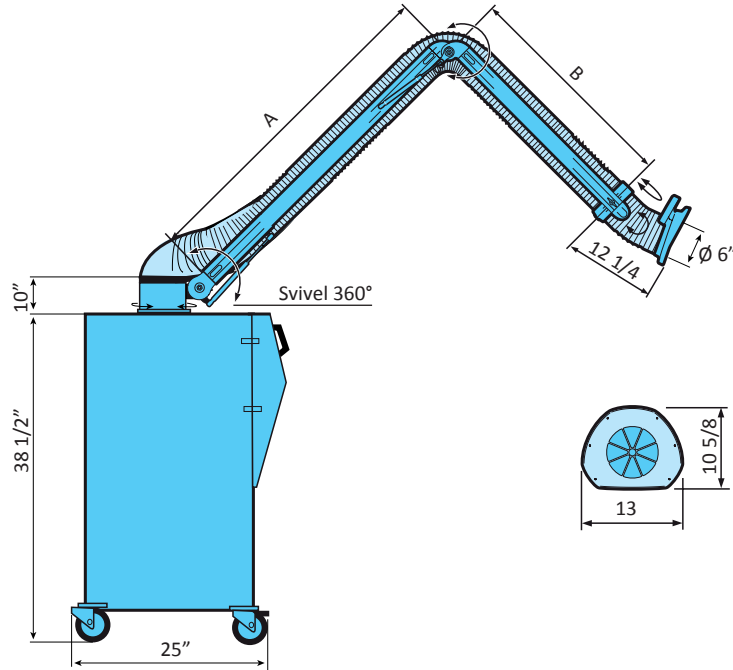

Part no:	A (inches)	B (inches)	Ø (inches)	Weight (lb)
MF 2000	37 1/2	19	6	148
MF 3000	57	39	6	152

Performance

Capacity about 705 cfm with PR-arm Ø6"

Motor Power 1-phase 115 V ~ 60Hz

Filter

Filter standard >98% acc. to DOP
 Filter accessory Carbon filter
 Filter area 150 feet²

Filter house

Height x Width x Depth 37 3/4" x 18 1/2" x 25 1/4"

Hose

Qualities Non-inflammable, suitable for welding fumes and flue gas

Temperature range 15°F to +195°F

Gas spring

Work temperature +68°F
 Temperature range -40°F to 195°F

Other

Surface treatment of sheet metal parts Powder coating
 Weight 172 lb

Filter holder

Made of powder coated sheet steel with four pivot wheels (two lockable).

Filter

Cartridge filter, 2 layer, flame-resistant

Accessories

Carbon filter.

Hose

Made of spring coil completely embedded in PVC-coated polyamide fabric.

For other hose qualities, contact MOVEX.

Delivery Design

Supplied complete with cable and plug.

MOVEX®

Movex Inc., 104 Commerce Drive
 Northampton, PA 18067 USA

Phone: 610 440-0478 Fax: 610 440-0480

www.movexinc.com info@movexinc.com