



## MOVEX CFE and CFE W3 are dust filters for large airflows.

Movex CFE och CFE W3 are suitable for filtration of dry particles, such as dust and welding fumes, in the mechanical industry.

For airflows from 600 cfm to 7000 cfm. For larger air flows, multiple modules can be installed in parallel.

Two versions of the filter are available:

Standard filter cartridge designed for welding fumes from steel with a chrome/nickel content of less than 30%

**W3** Certified filter for filtration of welding fumes from stainless steel.

On-demand cleaning.

The filter is supplied fully assembled from the factory.

**W3** Filter replacement can take place without any contact with the dirty filter.

Monitoring system via a mobile app on your smartphone is available as an option.

To meet the requirements for installation in different environments, CFE is available in two versions of surface treatment:

- **CFEI** - Low risk for corrosion, for indoor installation, non-heated air, varying temperature.
- **CFEO** - High risk for corrosion, for outdoor installation, polluted city- and coastal areas.

*The Movex range also includes fans, local extraction, accessories, control units and filters*

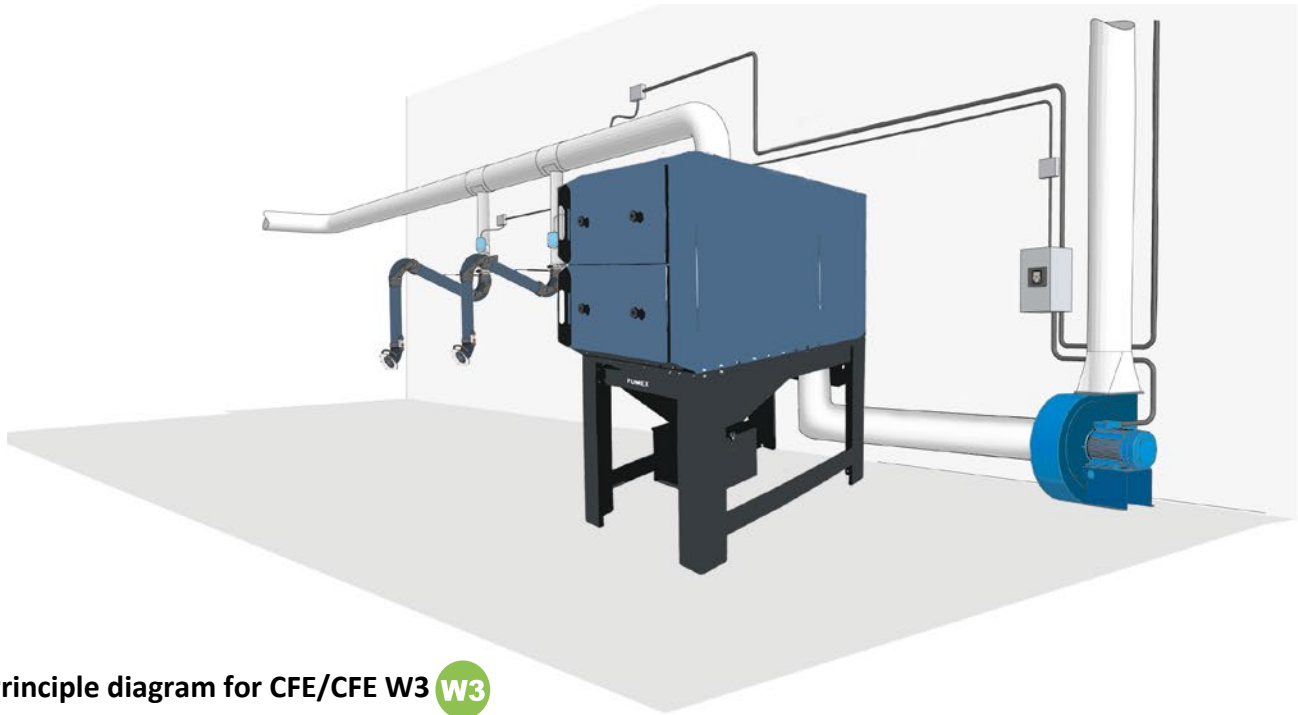

## Principle diagram for CFE/CFE W3 **W3**

A Movex PRX local extractor is used to evacuate the welding fumes. To conserve energy and extend the life of the filter, the extractor is equipped with automatic shut-off dampers that close when the extractor is not in use.

Particles are filtered via Movex CFE/CFE W3 type filter in accordance with standard EN ISO 15012-1, W2 or W3.

The speed of Movex FB type fan is controlled via a ST 300 pressure sensor and an SFC frequency converter.

The filter can be equipped with a monitoring system that connects to an app on your smartphone to monitor the function of the filter.

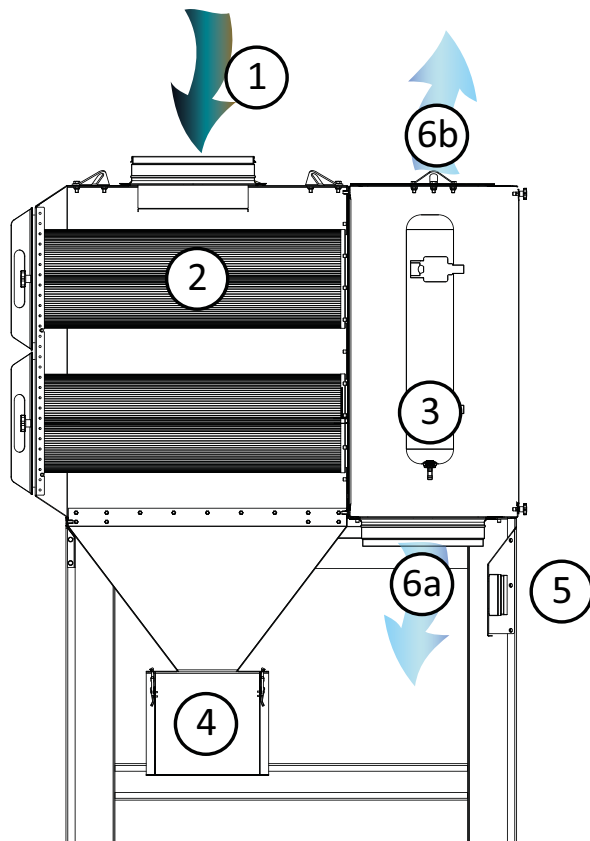

### How the cartridge filter works

1. The contaminated air comes in from above. The dust moves naturally through the filter.
2. The filter cartridges separate the dust with a high degree of separation efficiency. The horizontal position of the filter cartridge facilitates accessibility during service work. Filter replacement can take place without any contact with the dirty filter.
3. A pressure-controlled diaphragm valve provides blasts of compressed air to dislodge the dust that collect on the cartridge.
4. Dust that is dislodged from the filter cartridges is collected in the straining compartment and falls down into the dust collector.
5. Control and compressed air components are positioned externally for easy access and are well recessed to protect against mechanical impact.
6. The filtered air passes through the outlet. The outlet connection is downwards facing as standard (6a), but can also be supplied with the connection facing upwards (6b). The outlet position can also be altered during installation.

## Automatic system with on-demand cleaning



**On-demand cleaning**, controlled by the pressure drop across the filter cartridges. The pressure drop starts a cyclical cleaning of the cartridges when the set value is reached.

**Online cleaning.** To ensure stable airflow, the filter is cleaned during operation (so-called online cleaning). When the fan stops for breaks or at the end of the working day, the filter is cleaned (so-called offline cleaning) to allow all lightweight particles to fall into the dust collector.

**Control unit.** The status of the cartridges can be checked by reading the digital control unit on the filter or by installing the external manometer, CFE M. For remote monitoring on your smartphone or PC, a separate device is available as an accessory.

**W3-certified filters (CFE W3)** must always be monitored using a CFE BW3 warning light placed in a highly visible location indoors.

**Programmable control unit**, for programming e.g. start-up pressure for cleaning and number of cleaning cycles after the system has stopped.

**Isolating switch**, for electrical connection of the control unit.

**Compressed air valve**, for setting desired cleaning pressure and fitted with locking shut-off valve. The evacuation valve for the compressed air tank is separate.

**The controls are already connected**, only compressed air and single phase (230 V) electrical connection are required.

## Certificate for **W3**

According to standard EN ISO 15012-1

Evacuating the harmful welding fumes directly at the source, before they spread into the premises, is the most effective way of creating a healthy and safe working environment.

The level of harmful and carcinogenic particles in the welding fumes is rising at the same rate as the increase in the percentage of chrome/nickel (Cr Ni) alloys in the welding wire. This means that systems for welding fume extraction and filtration are subject to more stringent requirements.

The international standard EN ISO 15012-1 specifies the requirements for filtering welding fume particles in the following categories.

**W3** Filtration of welding fumes from steel with a chrome/nickel (Cr Ni) content equal to or greater than 30% must have certified separation of more than 99%.

**W2** Filtration of welding fumes from steel with a chrome/nickel (Cr Ni) content lower than 30% must have separation of more than 98%.



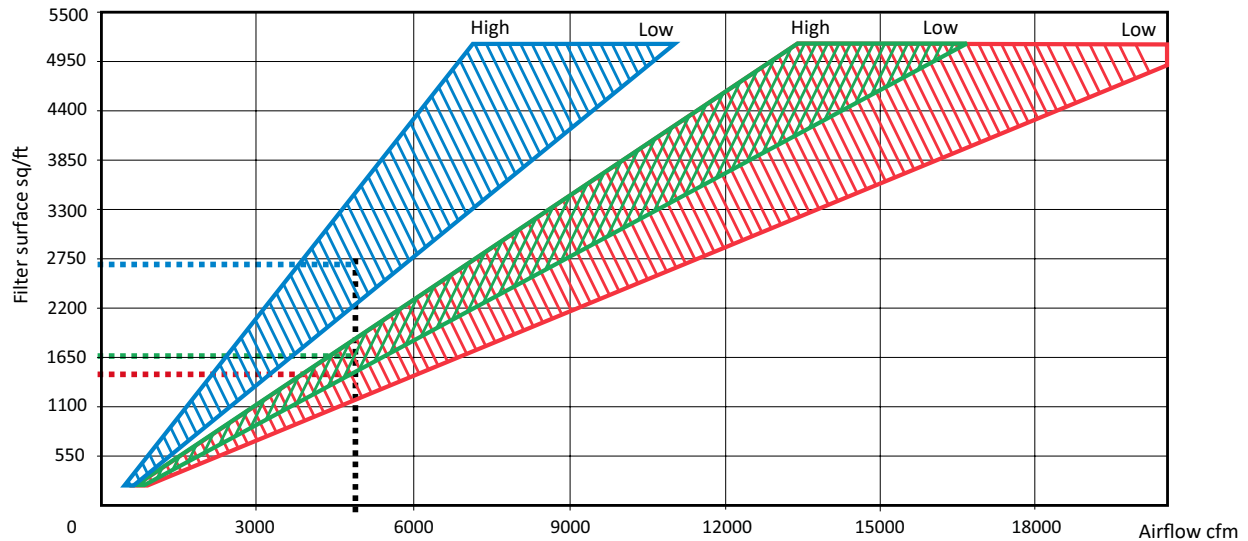

## Air quantities and filter load



The air volume for each filter is calculated on the basis of what is known about the nature of the dust particles, the amount of dust in the air and how intensively the system is being used. Based on experience, the following filter loads are recommended.

 Fumes from plasma, gas and laser cutting  
Filter load 1.5–2.2 cfm/ft<sup>2</sup>

 Fumes from welding (production).  
Dust from fine dust and powder  
Filter load 2.7–3.2 cfm/ft<sup>2</sup>

 Fumes from welding (training, repair work).  
Dust from metalwork and stonework  
Filter load 2.7–4.3 cfm/ft<sup>2</sup>

The pressure drop of the filter in clean cartridges is 1–2 in/wg depending on the volume of air.

Recommended pressure drop at which the filter should be replaced: 6 in/wg



Maximum pressure drop over the cartridges: 7 in/wg

## Filter cartridges

Standard filter CFS 195/CFS 195W3 is recommended in normal circumstances.

For demanding applications (gas and plasma cutting), the high-quality filter CF 168PH is recommended.

	CFS 195	CFS 195P	CF 168PH
Description	Standard filter. Used for welding fumes and for dust from stone and metal.	Standard filter. Used for welding fumes and for dust from stone and metal. The robust polyester fiber provides longer service life. Particularly suitable for frequent cleaning and long operating hours.	A high-quality filter for demanding applications, e.g. gas and plasma cutting. Also suitable for demanding dust filtration with high concentrations of dust.
Material:	Polyester - standard	Polyester - BICO	Polyester
Type:	Pleated filter material for optimum efficiency.	Pleated filter material for optimum efficiency.	Corrugated filter material for maximum efficiency at the lowest pressure drop.
Max temp. process air:	140°F	140°F	160°F
Filter material's degree of penetration according to EN-60335-2-69	0.06%	0.06%	0.06%
Dust class:	M(BIA)	M(BIA)	M(BIA)
Active filter area:	210 feet <sup>2</sup>	210 feet <sup>2</sup>	180 feet <sup>2</sup>

	CFS 195W3 	CF 211W3 
Description	Standard filter. Used for welding fumes and for dust from stone and metal. The PTFE membrane makes the filter suitable for slightly damp or sticky material.	A high-quality filter for demanding applications, e.g. gas and plasma cutting. Also suitable for demanding dust filtration with high concentrations of dust.
Material:	Polyester - BICO with PTFE membrane.	Polyester, coated with nanofibre.
Type:	Pleated filter material for optimum efficiency.	Corrugated filter material for maximum efficiency at the lowest pressure drop.
Max temp. process air:	140°F	140°F
Filter material's degree of penetration according to EN-60335-2-69	0.01%	0.02%
Dust class:	E 10 (EN 1822)	E 10 (EN 1822)
Active filter surface area:	210 feet <sup>2</sup>	225 feet <sup>2</sup>

We always recommend to use pre-coating to extend the life-time of the filter cartridges.

# MOVEX CFE

## Dimensional drawing

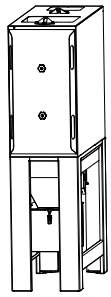

**CFE 2**  
**CFE 2W3 W3**

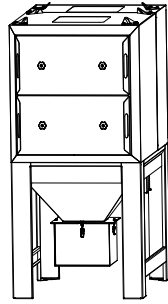

**CFE 4**  
**CFE 4W3 W3**

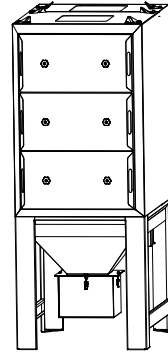

**CFE 6**  
**CFE 6W3 W3**

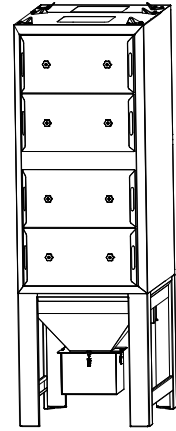

**CFE 8**  
**CFE 8W3 W3**

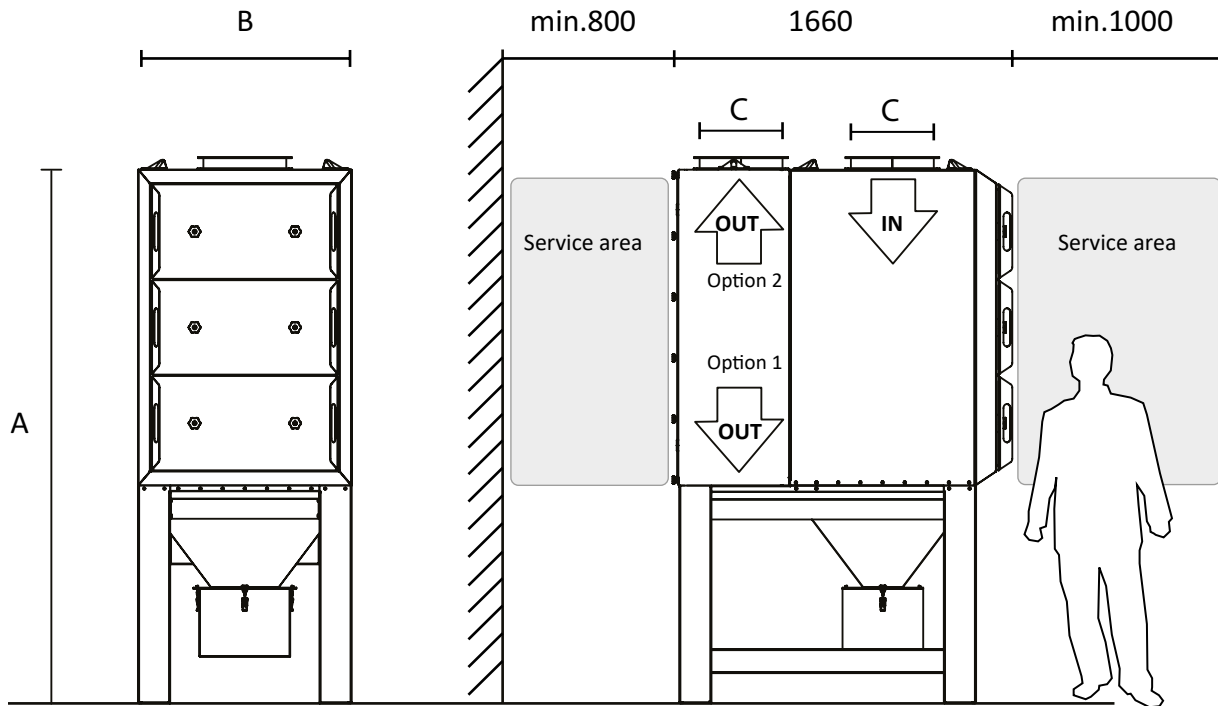

Designation	Number of cartridges	A inch	B inch	C inch	Weight lb
CFE 2	2	84 <sup>1/4</sup>	21 <sup>5/8</sup>	Ø10	595
CFE 4	4	85 <sup>13/16</sup>	42 <sup>1/8</sup>	Ø16	770
CFE 6	6	104 <sup>5/16</sup>	42 <sup>1/8</sup>	Ø16	1150
CFE 8	8	128 <sup>3/4</sup>	42 <sup>1/8</sup>	Ø16	1590

Designation	Number of cartridges	Filter area (ft <sup>2</sup> )			
		CFS 195	CF 168PH	CFS 195W3 W3	CF 211W3 W3
CFE 2	2	420	355	420	452
CFE 4	4	840	721	840	904
CFE 6	6	1260	1076	1260	1356
CFE 8	8	1680	1442	1680	1808

# MOVEX CFE

## Accessories to CFE and CFE W3

- W3 CFE BW3**  
Flashing orange warning light to indicate that the filter's maximum load has been reached. Supplied as a kit containing a warning light and relay box. Position in a highly visible location indoors. Included as standard for W3 type filter. **Delivered as standard with CFE W3.**



- W3 CFE RW3**  
Bayonet ring for contactless replacement of filter cartridges. Supplied with rubber bands for the plastic bag.



- W3 CFE PCW3**  
Plastic bag for contactless replacement of filter cartridges.



- W3 CFE PSW3**  
Plastic bag for contactless replacement of dust collector.

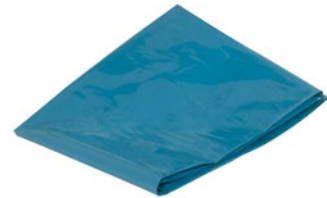

### CF PRECOAT/S and CF PRECOAT/H

Pre-coating is recommended to extend the life-time of the filter cartridges.

**CF PRECOAT/S**, recommended amount is 2 lb per standard cartridge filter  
**CF PRECOAT/H**, recommended amount is 1/3 lb per high quality cartridge filter

### CFE M

Analog pressure gauge for easy overview of filter load.



### CFE HS

Set of wheels for easy replacement of dust collector. Fits CFE 4, 6 and 8.



### CFT-400

To reduce the risk of sparks from welding or cutting reaching the filter cartridges, external spark trap CFT-400 is recommended.

To achieve the best effect, spark trap CFT-400 should be mounted in a horizontal position. The duct before the spark trap must have a straight part which is at least 10 x the duct diameter.

The spark trap is available in other sizes upon request.

Recommended speed: 25- 83 ft/s.  
Pressure drop at 50ft/s: 0.052 PSI  
Weight: 16 lb





## Technical data

### CFE filter

Maximum negative pressure for filter housing.....	0.73 PSI
Dust collector volume.....	14.5 gallons

### Material

Module	Casing and frame made from powder-coated sheet steel
--------	--

### Compressed air

Air consumption.....	Min. 8.5 ft <sup>3</sup> /min.
Max. pressure.....	102 PSI
Normal working pressure.....	70 PSI

### Automated functions

Pulse time.....	0.08
Ambient temperature.....	-4 to +122°F
Voltage.....	110 V ~ IN
Valve voltage.....	24 V ~ IN
Protection class.....	IP 54

### Form of delivery

Filters are always delivered fully assembled. Each module is equipped with lifting eyebolts for easy handling.

### Installation

The CFE filter is designed to be assembled before the fan. The filter must be weather-proofed with a built-in or lean-to roof. Connection should be made to a circular, pressure-tight duct.

### Air volume filter

Adjustments can be made using Movex pressure controls or flow controls.

### Compressed air

Air quality: Clean and oil-free air, free from condensation at the current working temperature.

# MOVEX